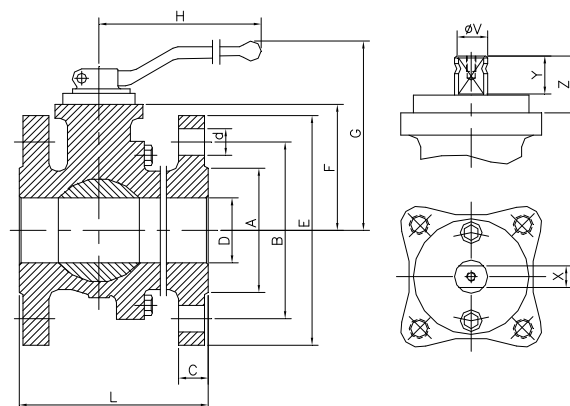
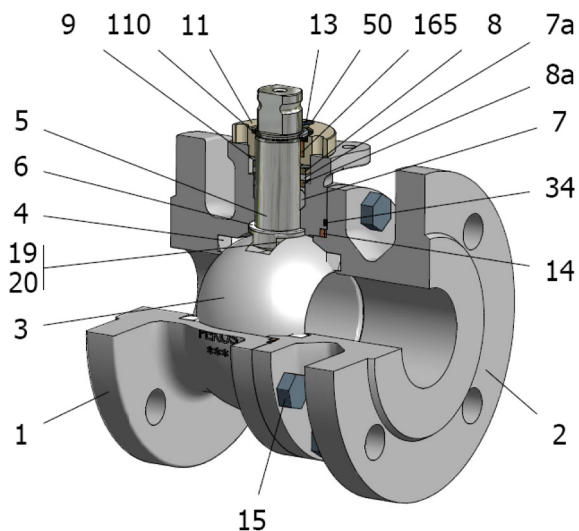

FIG.Z 06 TTTG PN40 DN15/125 F4-F5



Position	Description	Material
01	Body 1	S.S. 1.4408
02	Body 2	S.S. 1.4408
03	Ball	S.S. 1.4408
04	Seat	PTFE
05	Stem	S.S. 1.4401
06	Stem seal	PTFE+FG
07	Stem packing 1	PTFE
07a	Stem packing 2	Graphite
08	Gland packing 1	S.S. 1.4401
09	Spring washer	S.S. 1.4310
11	Cover	S.S. 1.4408
13	Cover bolt	A4-70
14	Body seal 1	PTFE
15	Body bolt	A4-70
16	Handle	WCB
17	Handle bolt	1045(8.8)
19	Spring	S.S. 1.4319
20	Ball	S.S. 1.4401
34	Body seal 2	Graphite
50	Subjection ring	S.S. 1.4301
110	Subjection ring seal	S.S. 1.4401 Nitrided
165	Stem bearing	PTFE+FG

General features

- Floating ball.
- Split body.
- Full bore.
- Soft seat.
- Bidirectional.
- Fire Safe.
- TA-LUFT.
- Anti Blow out proof stem.
- Autoadjustable packing.
- Anti static device.
- Self-cavity pressure relief.

Standards

- Top flange ISO 5211
- Flanges EN 1092-01
- Face to face EN 558
- Testing EN-12266, ISO 5208
- Design EN-12516, ISO 17292

Official approvals

- CERTIFICATE FIRE SAFE
- TÜV.AD-MERKBLATT WO
- TA-LUFT
- ATEX 94-9EC
- PED 97/23/CE.
- SIL 3
- EN 161/EN 264

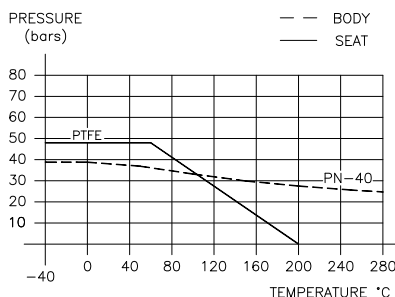

PEKOS GROUP CERTIFICATES:

ISO 9001-2008 / 97-23-CE /API-6D



DIMENSIONS & Technical information

DN	PN	D	L	E	A	B	C	F	H	G	V	X	Y	Z	n x d	ISO 5211	Torque	Weight
15	40	15	115	95	45	65	16	52	185	100	14	11	11	13,5	4 x 14	F05	12	3,0
20	40	20	120	105	58	75	18	54	185	102	14	11	11	13,5	4 x 14	F05	14	3,8
25	40	25	125	115	68	85	18	60	185	110	18	14	17	19,5	4 x 14	F05	17	4,7
32	40	32	130	140	78	100	18	65	185	115	18	14	17	19,5	4 x 18	F05	30	6,5
40	40	40	140	150	88	110	18	75	293	129	22	17	20	30	4 x 18	F07	40	8,2
50	40	50	150	165	102	125	20	83	293	137	22	17	20	30	4 x 18	F07	65	11,2
65	40	65	170	185	122	145	22	96	293	150	22	17	20	30	8 x 18	F07	85	16,9
80	40	80	180	200	138	160	24	114	350	187	28	22	22	40	8 x 18	F10	130	22,2
100	40	100	190	235	162	190	24	128	350	201	28	22	22	40	8 x 22	F10	190	30,0
125	40	125	325	270	188	220	26	158	680	247	36	27	35	50	8 x 26	F12	350	62,0

* Dimensions are in mm.

* Torque is in Nm.

* Weight is in Kilograms